

ZODIAC EQUIPMENT

LIFTING PLATFORM FOR PASSENGER STAIRS CDS PRM

This lifting platform is designed to carry one person with reduced mobility who is able to sit down (independently or with help) on the lift folding chair or is already sitting on a wheelchair.

- Latch catcher provides immediate platform stop during an uncontrolled increase speed (set at 0.3 m / s)
- The platform is an integral part of the stairs and cannot be added separately



Platform floor size (mm)	Weight (kg)	Max. platform load (kg)	Max. seat load (kg)	Speed (m/s)
800x800	300	300	150	0,1

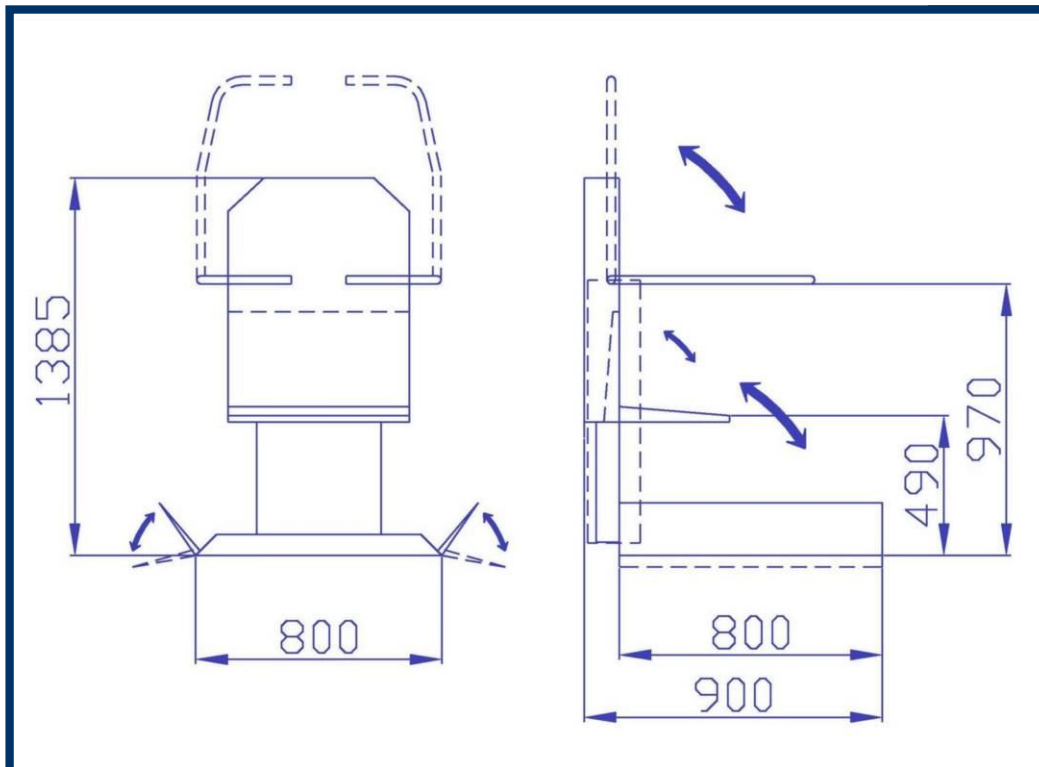

This product meets the EN 12312 standard

ZODIAC EQUIPMENT

LIFTING PLATFORM FOR PASSENGER STAIRS
CDS PRM



The platform is equipped with foldable floor, seat, barriers and loading ramps.

Fastening belt serves to strap persons carried on the seat.

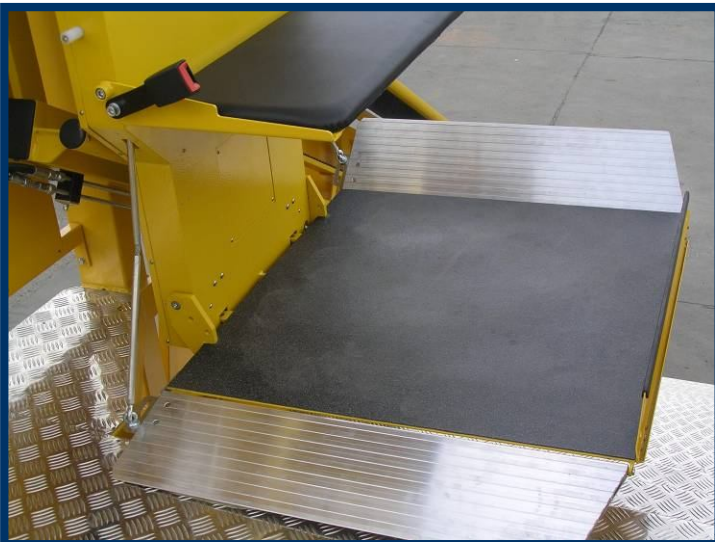

ZODIAC EQUIPMENT

LIFTING PLATFORM FOR PASSENGER STAIRS CDS PRM

Travel path consists of two beams welded steel profiles, which are hinged to each other. These beams are fixed to the structure of stairs. The slideway for drive chains is part of the top rail. The lower beam is adapted to guide the energy chain with electric cables.



Folded platform does not interfere the stairs common use.

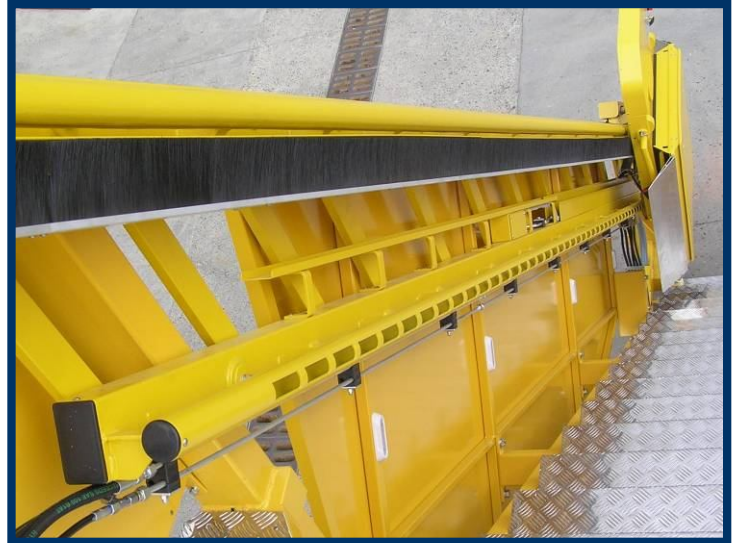

Retainer automatically stop movement of the platform downward in case of breaking load chains or other defect resulting in speed increase beyond limit. The latch is locked into one of the holes in the bottom rail track and stop motion.

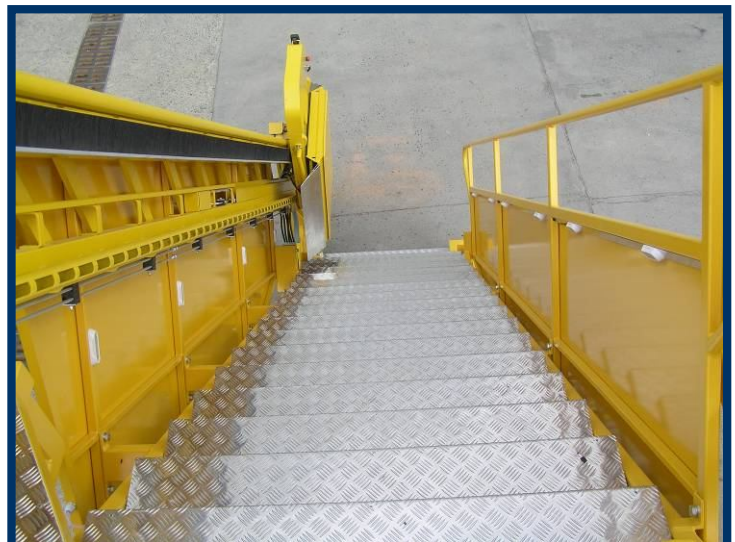

Vertical positioning allows to equalize differences in heights of lower platform stopover in dependence on surrounding terrain and different stairs inclination.

ZODIAC EQUIPMENT

LIFTING PLATFORM FOR PASSENGER STAIRS CDS PRM



Platform movement can be stopped anytime by stop movement button. Another way to stop device movement is to press any of emergency stop buttons.



External control buttons are placed on bottom end of travel path. These are used for calling or dispatching platform from or into parking position.



Handheld controller is used to control the platform traveling up and down. It is connected by coiled cable which allows operating from behind or in front of the platform.

