

# ZODIAC EQUIPMENT

## AIRCRAFT WHEEL SERVICE CART WSC

Our heavy-duty tire and wheel service cart features sturdy steel construction. The trolley offers a long-lasting reliability, easy operation and low maintenance costs. The totally enclosed Wheel Service Cart is designed for road use as well as airport apron and perimeter service roads. This cart offers the complete service facility for wheel change requirements and is capable of housing two main landing gear wheels, two front wheels, trolley jack and on board nitrogen charging facilities. Front axle steered by turntable steering, rear axle fixed.



Loading platform size (mm)	Payload (kg)	Weight (kg)	Max. towing speed (km)
2400 x 1700	2000	590	25

Platform size and its payload can be modified according to customer requirements

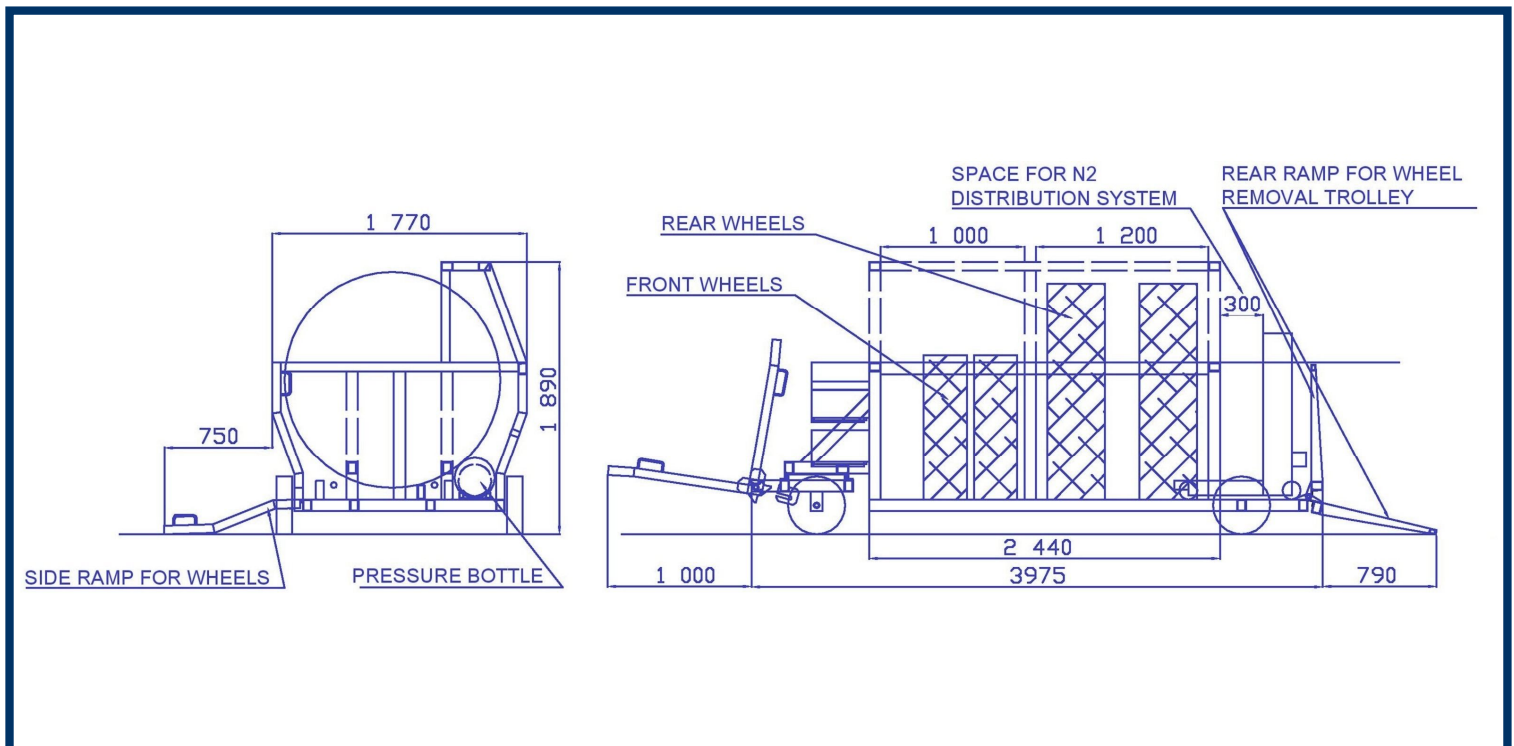

This product meets the EN 1915-1 standard



The design allows ease of loading and unloading via the lightweight assisted folding ramps that offer the ideal gradient to load and unload heavy, wide body landing wheels.



Interior is covered with a tarp secured by rubber straps and Velcro fasteners.

